

# EWTSPPlus 990

## Programmable electronic timer



by Schneider Electric

### USER INTERFACE



EWTSPPlus 990

● <b>cnt LED</b>	Quick flashing	Parameter programming	● <b>Separation LED</b>	ON	separation between hours/minutes, minutes/seconds, seconds/hundredths
	Flashing	Counting in progress		OFF	Counting stopped, terminated or reset
● <b>out1 LED</b>	ON	Output ON	● <b>out2 LED</b>	ON	Output ON
	OFF	Output OFF		OFF	Output OFF

**NOTE:** When switched on, the device performs a Lamp Test; the display and LEDs will flash for several seconds to check that they all function correctly.

### KEYS

<p><b>UP</b></p> <p><b>Press and release</b></p> <ul style="list-style-type: none"> <li>• Scroll menu items</li> <li>• Increases values</li> </ul> <p><b>Press for at least 5 secs</b></p> <ul style="list-style-type: none"> <li>• Function can be configured by the user (see parameter <b>H31</b>)</li> </ul>	<p><b>DOWN</b></p> <p><b>Press and release</b></p> <ul style="list-style-type: none"> <li>• Scroll menu items</li> <li>• Decrease values</li> </ul> <p><b>Press for at least 5 secs</b></p> <ul style="list-style-type: none"> <li>• Function can be configured by the user (see parameter <b>H32</b>)</li> </ul>	<p><b>STAND-BY (ESC)</b></p> <p><b>Press and release</b></p> <ul style="list-style-type: none"> <li>• Returns to the previous menu level</li> <li>• Confirms parameter value</li> </ul> <p><b>Press for at least 5 secs</b></p> <ul style="list-style-type: none"> <li>• Function can be configured by the user (see parameter <b>H33</b>)</li> </ul>	<p><b>set</b></p> <p><b>SET (ENTER)</b></p> <p><b>Press and release</b></p> <ul style="list-style-type: none"> <li>• Accesses 3 Set points Confirms commands Accesses menus</li> </ul>
--	---	---	--

### ELECTRICAL CONNECTIONS

#### ⚡ ⚠ DANGER

#### HAZARD OF ELECTRIC SHOCK, EXPLOSION OR ARC FLASH

- Disconnect all power from all equipment including connected devices, prior to removing any covers or doors, or installing or removing any accessories, hardware, cables, or wires.
- Always use a properly rated voltage sensing device to confirm the power is off where and when indicated.
- Replace and secure all covers, accessories, hardware, cables and wires.
- Use only the specified voltage when operating this device and any associated products.
- Do not connect the equipment directly to the line voltage, except where indicated otherwise.
- For the 12 Vac version, use insulated SELV (Safety Extra Low Voltage) power supply sources.
- Only use batteries with a rated voltage that corresponds to the specifications.

**Failure to follow these instructions will result in death or serious injury.**

#### ⚡ ⚠ DANGER

#### LOOSE WIRING CAUSES ELECTRIC SHOCK

Tighten connections in conformance with the torque specifications.

**Failure to follow these instructions will result in death or serious injury.**

mm in.	7 0.28							
mm <sup>2</sup>	0.2...2.5	0.2...2.5	0.25...2.5	0.25...2.5	2 x 0.2...1	2 x 0.2...1.5	2 x 0.25...1	2 x 0.5...1.5
AWG	24...13	24...13	22...13	22...13	2 x 24...18	2 x 24...16	2 x 22...18	2 x 20...16
		N•m		0.5...0.6				
Ø 3.5 mm (0.14 in.)		lb-in		4.42...5.31				

The table below displays the type and the size of cables for screw terminals with pitch **5.00 mm (0.197 in.)** or **5.08 mm (0.2 in.)**.

#### ⚡ ⚠ DANGER

#### POTENTIAL OF OVERHEATING AND FIRE

- Do not use with loads other than those indicated in the technical specification.
- Do not exceed the maximum permitted current; for higher loads, use a contactor with sufficient power capacity.

**Failure to follow these instructions will result in death or serious injury.**

This device is designed to operate outside of any dangerous location.

#### ⚡ ⚠ DANGER

#### POTENTIAL FOR EXPLOSION

Install this device only in areas known to be free from dangerous atmospheres.

**Failure to follow these instructions will result in death or serious injury.**

Electrical equipment should be installed, operated, serviced, and maintained only by qualified personnel. No responsibility is assumed by Eliwell for any consequences arising out of the use of this material.

## ⚠ WARNING

### UNINTENDED EQUIPMENT OPERATION

- Use appropriate safety interlocks where personnel and/or equipment hazards exist.
- Install and operate this equipment in an enclosure appropriately rated for its intended environment.
- Power line and output circuits must be wired and fused in compliance with local and national regulatory requirements for the rated current and voltage of the particular equipment.
- Do not use this equipment in safety-critical machine functions.
- Do not disassemble, repair, or modify this equipment.
- Do not mount devices in extremely damp and/or dirt-laden areas.

**Failure to follow these instructions can result in death, serious injury, or equipment damage.**

## ⚠ WARNING

### UNINTENDED EQUIPMENT OPERATION DUE TO CONNECTION

Signal leads (probes, digital inputs, communication and the signal electronic supply) must be routed separately from power and supply cables.

**Failure to follow these instructions can result in death, serious injury, or equipment damage.**

## MOUNTING - DIMENSIONS

The device is designed for panel mounting. Drill a 71x29 mm (2.80x1.14 in.) hole and insert the instrument; secure it with the special brackets provided. Do not install the instrument in damp and/or dirty places; in fact, it is suitable for use in places with ordinary or normal levels of pollution. Keep the area around the instrument cooling slots adequately ventilated.

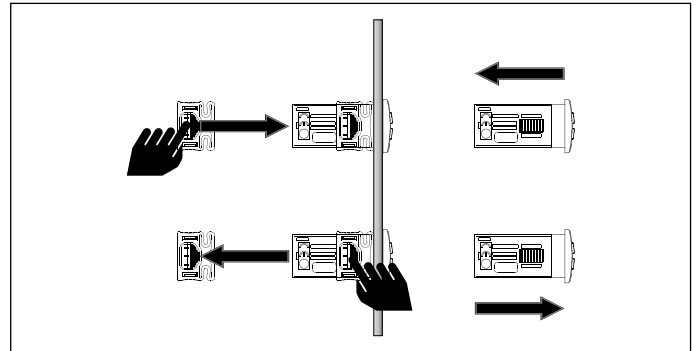
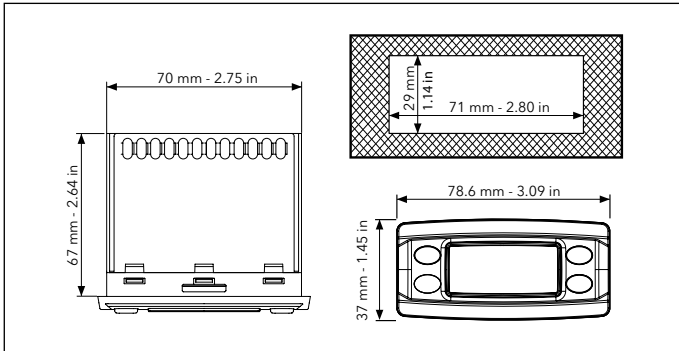

## CONNECTION

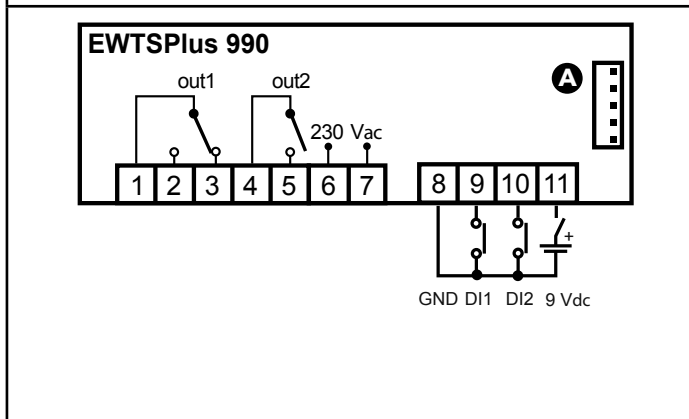
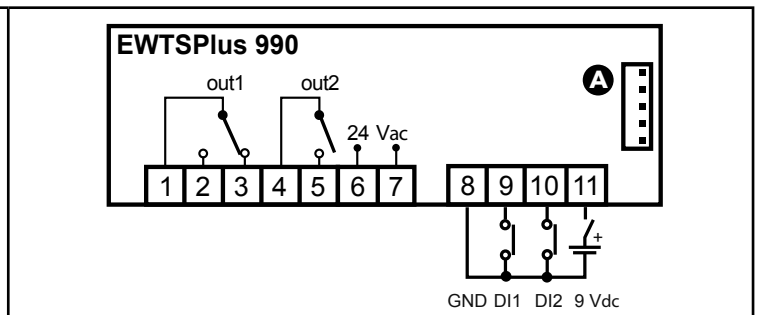
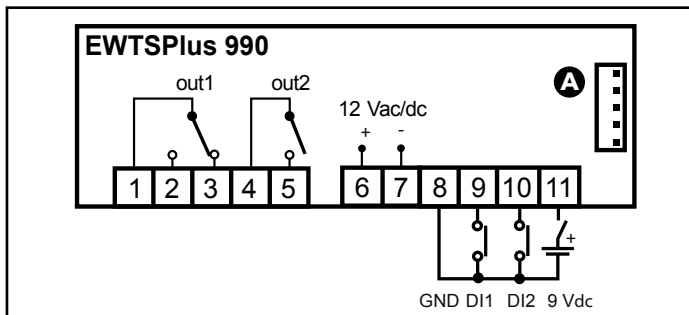

TERMINALS	
1-2	N.O. relay output OUT 1 see par. <b>H21</b>
1-3	N.C. relay output OUT 1 see par. <b>H21</b>
4-5	N.O. relay output OUT 2 see par. <b>H22</b>
6-7**	Power supply
8-9	Digital input D.I.1 see par. <b>H11</b>
8-10	Digital input D.I.2 see par. <b>H12</b>
8-11	External battery 9 Vdc
<b>A</b>	TTL input for Copy Card and connection to TelevisSystem
**	Available in 3 different power supplies: 12 Vac/dc ±10 % o 24 Vac o 230 Vac ±10 % 50 /60 Hz

## TECHNICAL DATA (EN 60730-2-9)

Classification:	Electronic automatic control (not safety) device for incorporation
Mounting:	Panel mounting with 71x29 mm (+0.2/-0.1 mm) (2.80x1.14 in.) drilling template
Type of action:	1.B
Pollution class:	2
Insulation material group:	IIIa
Overvoltage category:	II
Nominal pulse voltage:	2500 V
Temperature:	Use: -5 ... 55 °C (23 ... 131 °F) - Storage: -30 ... 85 °C (-22 ... 185 °F)
Power supply:	- 24 Vac or 230 Vac (± 10 % 50/60 Hz) - 12 Vac/dc (±10%) 50/60 Hz - SELV (Safety Extra Low Voltage): Use a dedicated power supply source. Observe the DC power supply polarity.
Consumption:	3 VA (230 Vac / 24 Vac models); 1,5 W (12 Vac/dc model)
Fire resistance category:	D
Software class:	A



**NOTE:** check the power supply rating on the device's label; contact our Sales Office for power and relay ratings.



## FURTHER INFORMATION

Casing:	PC+ABS UL94 V-0 resin plastic body, polycarbonate front, thermoplastic resin buttons.
Dimensions:	front 78.6x37 mm (3.09x1.45 in.), 59 mm (2.32 in.) depth.
Operating and storage ambient humidity:	10...90 % RH (non-condensing).
Display range:	9999 hours, 99 hours and 59', 99' and 59", 99" and 99 hundredths.
Digital inputs:	2 voltage-free parameter configurable digital inputs.
Serial:	TTL for Copy Card or connection to TelevisSystem (Maximum length = 3 m / 9.84 ft).
Digital Outputs:	NO 8(4) A NC 6(3) A max 240 Vac
Accuracy:	3.6 sec/h
Consumption:	<ul style="list-style-type: none"> <li>• Power supply 9 Vdc,</li> <li>• battery duration: depending on model; with battery 9 Vdc / 10 mA/h duration 1 h,</li> <li>• instrument absorption with battery power: 10 mA.</li> <li>• Observe the battery polarity.</li> </ul>

## SETTING THE SETPOINT

**EWTSPlus 990** enables 3 set times to be specified, i.e. **t1**, **t2**, **t3**. To configure the set points, press the **set** button and quickly release it **t1** displays and the 'cnt' LED starts quickly flashing.

To select one of the other two set points, **t2**, and **t3**, press the  or  buttons.

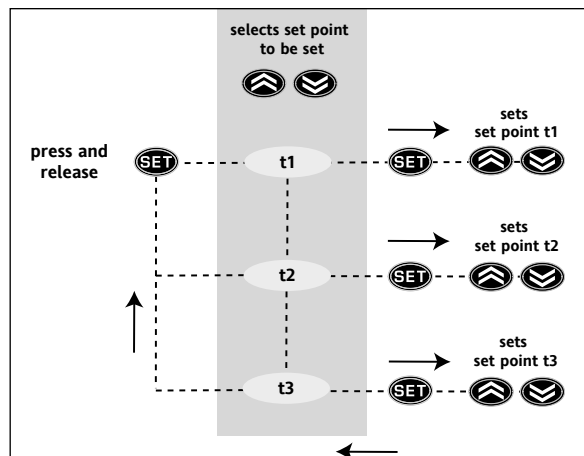

To change the set points, press **set** once more, then use the  or  buttons to change the value.

The set point configuration mode is automatically closed if no set button is pressed for approximately 15 seconds or if the  is pressed once. The count reached at that time then reappears on the display. Times can always be set, regardless of whether the counting is in progress or not.



## 'PROGRAMMING' MENU

To access the **'Programming'** menu, press the **set** key for more than 5 seconds. If specified, an access **PASSWORD** will be requested: **PA1** for **'User'** parameters and **PA2** for **'Installer'** parameters (see **'PASSWORD'** paragraph).

**User** parameters: By using the  or  buttons you can scroll through all the folders in the programming menu that only contain user level parameters (1).

**Installer** parameters: When accessed, the display will show the first folder. Press  and  to scroll through the folders on the current level. Select the desired folder using **set** key. Press  and  keys to scroll through the parameters in the current folder and select the parameter using **set**. Press  and  to modify it and press **set** key to save the changes.

**NOTE:** Switch the device off and on again each time the parameter configuration is changed.

## KEYBOARD LOCKED

Keyboard operating can be locked by programming the **LOC** parameter (see folder with **diS** table). If the keyboard is locked you can access the **Programming** Menu by pressing the **set** key. The set point can also be displayed.

## PASSWORD

Access to parameter handling both at user level and installer level can be limited by using passwords. The passwords can be enabled by setting the **PA1** (user password) and **PA2** (installer password) in the **diS** folder. The passwords are enabled if the value of the 2 parameters **PA1** and **PA2≠0**.

**Password PA1:** used to access 'User' parameters. The password is not enabled by default (**PA1=0**).

To access the "Programming" menu hold down the **set** button for more than 5 seconds. If specified, the user level (1) access PASSWORD will be requested. If password 1 is enabled (**PA1≠0**) you will be asked to enter it. Perform the operation by selected the correct value using the **↕** and **↘** keys and press the **set** button to confirm.

**Password PA2:** used to access 'Installer' parameters. The password is not enabled by default (**PA2=0**).

In the programming menu scroll through the folders containing the user level parameters using the **↕** and **↘** buttons until the **CnF** folder is displayed.

Press the **set** button to enter the **CnF** folder where the **PA2** label is present. Scroll through the folder parameters and press the **set** button next to the **PS2** label, '0' will appear on the display. Use the **↕** and **↘** buttons to select the correct value of the installer password and then press the **set** button to access the installer level parameters (2).

**NOTE:** If the password is not entered correctly, the device will display the **PA2** label again and the operation will have to be repeated.

At each level in both menus, when the **ⓘ** button is pressed or the 15 second time out elapses, you are taken back to the higher display level and the last value on the display is stored.

## USING THE COPYCARD

The Copycard is connected to the serial port (TTL) and allows rapid programming of the instrument parameters.

Access 'Installer' parameters by entering **PA2**, scroll through the folders using **↕** and **↘** until folder **FPr** appears.

Select it using **set**, scroll through the parameters using **↕** and **↘**, then select the function using **set** (e.g. **UL**).

- **Upload (UL):** Select **UL** and press **set**. This function uploads the programming parameters from the instrument to the card. If the procedure is a success **y**, will appear on the display, otherwise **n** will appear.
- **Format (Fr):** This command is used to format the Copycard, (recommended when using the card for the first time).  
**NOTE:** the **Fr** parameter deletes all data present. This operation cannot be cancelled.
- **Download:** Connect the Copycard when the instrument is switched off. At power-on, data is downloaded from the Copycard to the instrument automatically. At the end of the lamp test, the display will show **dLy** if the operation was successful and **dLn** if not.

**NOTE:** After downloading, the instrument works with the settings of the new map just downloaded.

### Download from reset

Connect the copy card when the instrument is OFF. The programming parameters are downloaded when the device is switched on. At the end of the lamp test, the following messages are displayed for about 5 seconds:

- **dLY** label if copy operation is successful;
- **dLn** label if operation fails.

### NOTE:

- after the parameters have been downloaded, the device uses the downloaded parameter map settings.
- see **FPr** folder in Parameter Table and Description of parameters.

## OPERATING

### COUNT COMMANDS

Counting is enabled/disabled using the **ⓘ** button on the front keypad (configured/disabled as START/STOP, par **H33=1**), or the CNT EN input. Counting is reset using the RESET input or the button configured as 'reset'.

Operation of the **ⓘ** button on the front keypad configured as START/STOP and the CNT EN input is controlled by the status of the 2 parameters **P10** and **P09** respectively (see parameter table).

The RESET input always stops and resets counting and also has priority over the other commands. Whilst the reset function is active, counts cannot be started. The **rLoc** label is displayed (with rapid flashing) rather than the normal display. Parameter **P08** controls device operating in the event of a power failure (see parameters table). When the instrument is able to continue counting even if there is a power failure, during counting in these conditions, the only active command is the RESET command that can only be enabled using the **ⓘ** button (configured for resetting, par. **H33=2**).

Counting cannot therefore be reactivated after being stopped when the instrument is battery powered.

### DISPLAY

The SET/CNT LED is used to indicate:

- the input being programmed (fast flashing);
- counting in progress (slow flashing);
- counting stopped before ending (permanently on);
- counting terminated and reset status (off).

After resetting, 0000 is displayed if the up counting mode is set (par. **P07=1**) or the set point value set if the down counting mode is set (par. **P07=2**) During counting the value of the time that elapses, up or down, will be displayed. THE **ddd** parameter can be used to display the **t3** time, up or down.

If the back-up mode is set to continue counting even if there is a power failure (par. **P08=2**) the 2 central LEDs remain permanently on if counting has stopped, there is a power-down or an external battery is connected. If counting was in progress the two LEDs flash once a second while the display is off.

### STAND-BY CONTROLLER

The Stand-by controller can be enabled using the digital input if it is suitably configured (**H11-12**), or the specially programmed button (**H31, 32, 33**). The **H08** parameter can be used to select the Stand-by operating mode:

- **H08=0:** In off mode the display stays on and all controllers are disabled.
- **H08=1:** In off mode the display is switched off and all controllers are disabled.
- **H08=2:** In off mode 'OFF' appears on the display and all controllers are disabled.

Each time the device is switched off the cycle times are reset.

## OUTPUT OUT1 OPERATING

The instrument can be programmed using parameter **P01** to operate in 5 different modes:

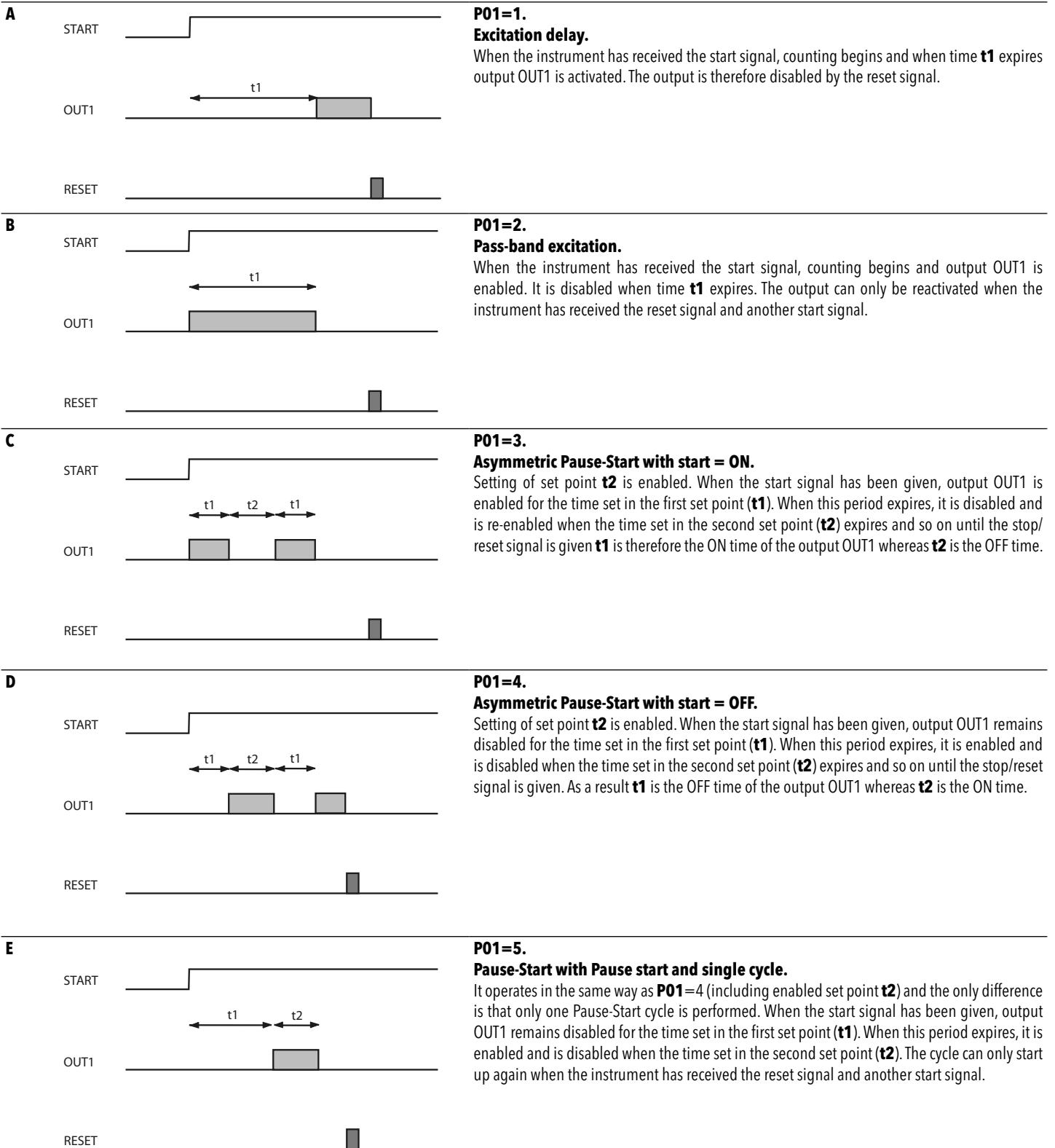

## TELEVISSYSTEM

### BusAdapter150

TTL - RS-485 serial interface on DIN rail for connecting the device and an RS-485 network designed for connection to Televis or ModBUS supervision system.

### PCInterface2150/2250

RS-232/RS-485 serial interface for connecting a PC and a series of instruments in an RS-485 network. The device needs the BlueCard activation module supplied with the Eliwell software package licence to be plugged in.

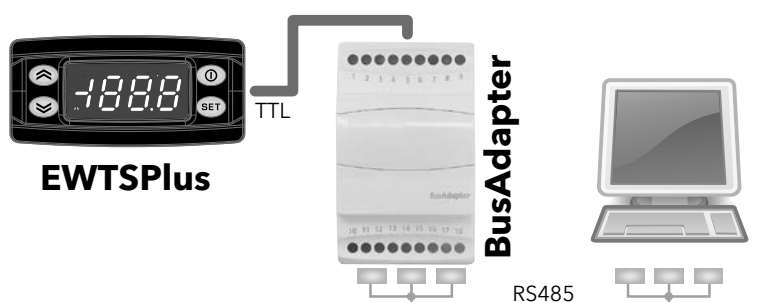

# OUTPUT OUT2 OPERATING

The instrument can be programmed using parameter **P02** to operate in 4 different modes:

- A P02=0.** Output OUT2 is always disabled.
- B P02=1.** Output OUT2 operates in exactly the same way as OUT1 so that it has a dual output contact.

**P02=2.**

**Output OUT2 operating as instantaneous contact.**

The output OUT2 is enabled during counting and remains active until the reset command is given.

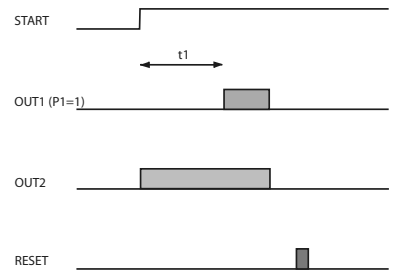

**C**

**P02=3.**

**Operates in same way as P01 (time t1) but time t3 is absolute.**

With **P02 = 3** setting of set point **t3** is enabled. It has the same time scale as **t1** and cannot be greater than **t1**. When the instrument has received the start signal, it starts counting and operates on output OUT2 in exactly the same way that **P01** operates on output OUT1.

When setting time **t3**, **t3 i** is displayed to indicate that time **t3** is independent. As a result, if **P01=1, 4 or 5** the output OUT2 operates with the excitation delay function with time **t3**.

**D**

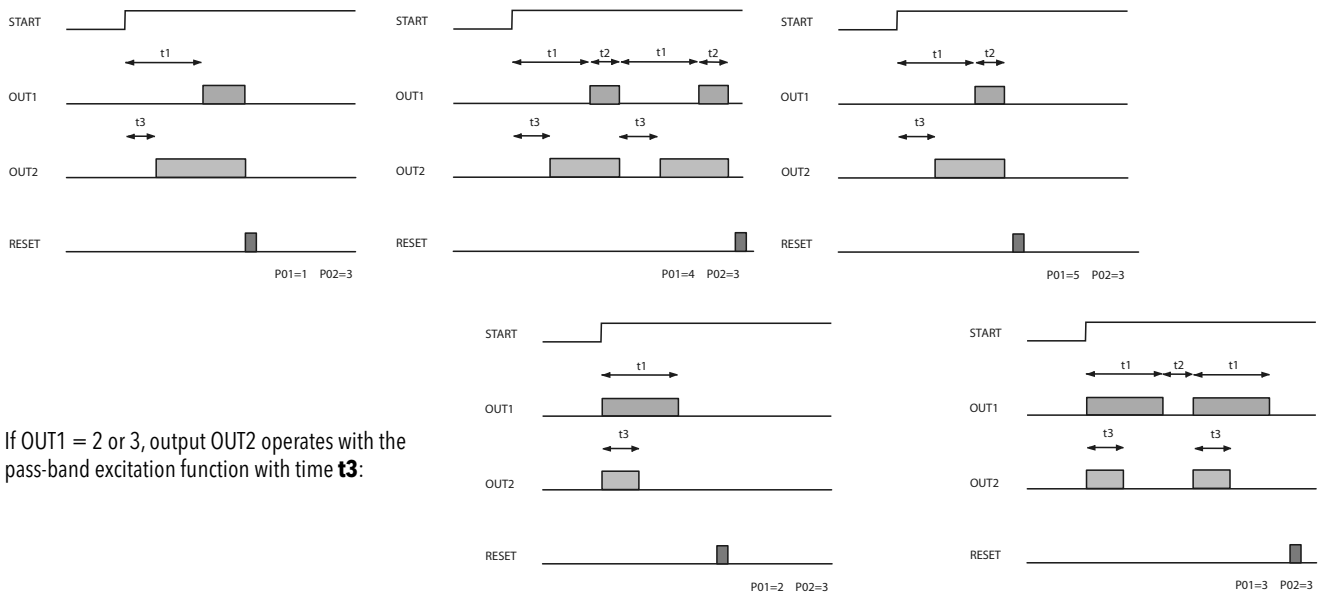

If **OUT1 = 2 or 3**, output OUT2 operates with the pass-band excitation function with time **t3**:

**P02=4.**

**Operates in same way as P01 (time t1) but with relative time t3 early.**

- E** With **P02 = 4** setting of set point **t3** is enabled. It has the same time scale as **t1** and cannot be greater than **t1**. When the instrument has received the start signal, it starts counting and operates on output OUT2 in exactly the same way that **P01** operates on output OUT1. When setting time **t3**, **t3 d** is displayed to indicate that time **t2** is independent. if **P01=2 or 3**, output OUT2 operates with the pass-band excitation function with time **t1-t3**:

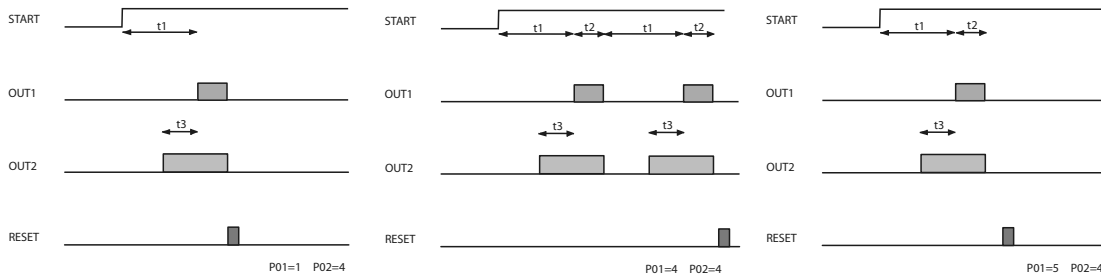

If **OUT1 = 2 or 3**, output OUT2 operates with the pass-band excitation function with time **t3**:

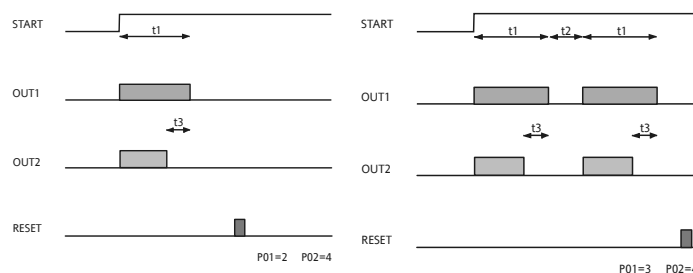

## CNT EN INPUT OPERATING

The start signal can be given using the START/STOP front button that usually has bistable functionality or the count enabling inputs IN\_ST\_SP. The IN\_ST\_SP input can be programmed using parameter **P09** to operate in 4 different modes:

**A**

**P09=1. BISTABLE START/STOP.**  
By sending an impulse to input IN\_ST\_SP, counting is enabled and when the next impulse is sent the counting will stop at the value it has reached. After another impulse the counting will restart from where it stopped until counting has been completed or the reset signal has been given.

**B P09=2 BISTABLE RESET-START/STOP**  
It operates in the same way as the START/STOP front button and also depends on par. **P10** that has two operating modes:

**P09=2, P10=1. RESET - START | STOP.**  
When the first impulse is supplied to input IN\_ST\_SP, the timer is reset and started whereas with the second impulse:

- If it is given before the end of counting, is stopped (disabling the output if active).
- If it is given after the end of counting, starts a new cycle.

**P09=2, P10=2. RESET / START | STOP.**  
When the first impulse is supplied to input IN\_ST\_SP the timer is reset whereas with the second impulse counting is started and stopped with the third.

**C**

**P09=3. MONOSTABLE START/STOP\*.**  
By enabling input IN\_ST\_SP and keeping it enabled, counting is started and stops on the value reached when the input is disabled. At this point, if the input is re-enabled, counting will restart from the value reached and so on until the reset signal is given.

**D**

**P09=4. MONOSTABLE RESET-START | STOP\*.**  
By enabling input IN\_ST\_SP and keeping it enabled, the timer resets, counting is started and then stops on the value reached when the input is disabled.

**\* In this operating mode the START/STOP front button only works as a reset button.**

## PARAMETERS TABLE

PAR	DESCRIPTION	RANGE	DEFAULT	LEV.	M.U.
t1	Set Point <b>t1</b> .	0...9999	1	/	hours/min/sec
t2	Set Point <b>t2</b> .	0...9999	1	/	hours/min/sec
t3	Set Point <b>t3</b> .	0...9999	1	/	hours/min/sec
<b>Programming – 'PrO' label</b>					
P01	Output OUT1 operating mode; establishes operating of output OUT1 for counting: <b>1</b> = Excitation delay; <b>2</b> = Pass-band excitation; <b>3</b> = Asymmetric oscillator (Pause-Start) start off; <b>4</b> = Asymmetric oscillator (Pause-Start) start on; <b>5</b> = Single cycle pause-start.	1...5	1	1-2	num
P02	Output OUT2 operating mode; establishes operating of output OUT2 for counting: <b>0</b> = Output not operating by enabling input CNTEN and keeping counting active; <b>1</b> = Operating as OUT1; <b>2</b> = Active during counting and will remain active until reset command; <b>3</b> = Same as OUT1 with time 2 independent; <b>4</b> = Same as OUT1 with time 2 independent.	0...5	0	1-2	num
P03	Time scale <b>t1</b> ; establishes unit of measurement of time <b>t1</b> (and <b>t3</b> if enabled): <b>1</b> = Hours (9999); <b>2</b> = Hours-min (99 hours/59 min); <b>3</b> = Min-sec (99 min/59 sec); <b>4</b> = Sec-hundredths (99 sec/99 hundredths).	1...4	1	1-2	num
P04	Time scale <b>t2</b> ; establishes unit of measurement of time <b>t2</b> : <b>1</b> = Hours (9999); <b>2</b> = Hours-min (99 hours/59 min); <b>3</b> = Min-sec (99 min/59 sec); <b>4</b> = Sec-hundredths (99 sec/99 hundredths).	1...4	1	1-2	num
P05	Time <b>t1</b> maximum set point; establishes the maximum value of the 2 most significant figures that can be set for set point <b>t1</b> .	0...99	99	1-2	hours/min/sec
P06	Time <b>t2</b> maximum set point; establishes the maximum value of the 2 most significant figures that can be set for set point <b>t2</b> .	0...99	99	1-2	hours/min/sec
P07	Counting mode; establishes if the counting must be UP or DOWN. <b>1</b> =UP; <b>2</b> =DOWN.	1...2	1	1-2	num
P08	Back-up mode; establishes the behaviour of the machine if there is a power failure: <b>1</b> = Stops counting and stores the value; <b>2</b> = Continues counting (only with battery present); <b>3</b> = Resets counting.	1...3	1	1-2	num
P09	CNT EN input operating mode; establishes operating of count enabling input: <b>1</b> = Bistable START STOP; <b>2</b> = Bistable RESET-START STOP; <b>3</b> = Monostable START/STOP; <b>4</b> = Monostable RESET-START STOP.	1...4	1	1-2	num
P10	START/STOP button operating mode: <b>0</b> = Non operational; <b>1</b> = RESET-START/STOP; <b>2</b> = RESET START/STOP; <b>3</b> = RESET only.	0...3	1	1-2	num

PAR	DESCRIPTION	RANGE	DEFAULT	LEV.	M.U.
<b>Communication - 'Add' label</b>					
<b>dEA (1)</b>	Device address in family.	0...14	0	1-2	num
<b>FAA (1)</b>	Device family.	0...14	0	1-2	num
<b>Display - 'dis' label</b>					
<b>LOC (2)</b>	Keyboard locked (blocks activation of primary functions) <b>n</b> (0) = Keyboard enabled; <b>y</b> (1) = Keyboard locked.	n/y	n	1-2	flag
<b>PA1</b>	Contains the password for access to level 1 parameters. Enabled if not 0.	0...255	0	1-2	num
<b>PA2</b>	Contains the password for access to level 2 parameters. Enabled if not 0.	0...255	0	2	num
The passwords are enabled if the value of the 2 parameters <b>PA1</b> and <b>PA2</b> is not 0.					
<b>ddd</b>	Display of fundamental state; determines display when instrument starts up: <b>0</b> = <b>t1/t2</b> ; <b>1</b> = <b>t3</b> .	0/1	0	1-2	flag
<b>Configuration - 'CnF' label</b>					
<b>H02</b>	Quick enabling time using configured buttons.	0...15	1	2	sec
Stand-By operating mode.					
<b>H08</b>	<b>0</b> = Display remains on and controllers are disabled; <b>1</b> = Display is turned off and controllers disabled; <b>2</b> = "OFF" is displayed and controllers are disabled.	0/1/2	2	2	num
<b>H11 (3)</b>	Configurability of digital input/polarity D.I.1. <b>0</b> = Disabled; <b>1</b> = CNT enable (reads front buttons); <b>2</b> = RESET (reads level); <b>3</b> = Stand By.	-3...3	-1**	2	num
<b>NOTE: H11 &amp; H12 MUST BE ALWAYS DIFFERENT</b>					
<b>H12 (3)</b>	Configurability of digital input/polarity D.I.2. Same as <b>H11</b> .	-3...3	-2**	2	num
<b>H21</b>	Digital output 1 configurability. <b>0</b> = Disabled; <b>1</b> = Out1; <b>2</b> = Out2.	0...2	1	2	num
<b>H22</b>	Digital output 2 configurability. Same as <b>H21</b> .	0...2	2	2	num
<b>H31</b>	UP button configurability. <b>0</b> = Disabled; <b>1</b> = START/STOP; <b>2</b> = RESET; <b>3</b> = Stand By.	0...3	0	2	num
<b>H32</b>	DOWN button configurability. Same as <b>H31</b> .	0...3	0	2	num
<b>H33</b>	Standby button configurability. Same as <b>H31</b> : in the event of a power failure, the only active command is the RESET command that can only be activated by the 'standby' button.	0...3	1	2	num
<b>rEL</b>	Device version. Read only parameter.	0...65535	1	1/2	num
<b>tAb</b>	Parameter table. Read only parameter.	0...65535	1	1/2	num
<b>Copy Card - 'Fpr' label</b>					
<b>UL</b>	Transfer of parameter map from instrument to Copy Card.	/	/	1/2	/
<b>dL</b>	Transfer of parameter map from Copy Card to ON and OFF.	/	/	1/2	/
<b>Fr (4)</b>	Formatting. Cancels all data on Copy Card.	/	/	1/2	/

#### NOTES:

- (1) The pair of values **dEA** and **FAA** represents the device network address and is indicated as "FF.DD" (where DD=**dEA** and FF=**FAA**).
- (2) When the keyboard lock is enabled the Set Point can only be displayed using the "set" button and the password-protected parameter programming menu accessed.
- (3) **NOTE:** positive or negative values change polarity, positive values: active input when the contact is closed; negative values: active input when contact is open.
- (4) If the Fr parameter is used, the data previously stored on the Copy Card will be permanently lost. This operation cannot be undone.

## LIABILITY AND RESIDUAL RISKS

ELIWELL CONTROLS SRL declines any liability for damage due to:

- installation/uses different from those specified and, in particular, not complying with the safety regulations and/or instructions given in this document;
- use on panels that do not provide adequate protection against electric shocks, water or dust when assembled;
- use on panels allowing access to dangerous parts without the use of tools;
- tampering with and/or modifying the product;
- installation/use on panels not complying with current standards and regulations.

## DISCLAIMER

This document is the exclusive property of ELIWELL CONTROLS SRL and may not be reproduced or circulated unless expressly authorised by ELIWELL CONTROLS SRL itself. Every care has been taken in preparing this document; nevertheless ELIWELL CONTROLS SRL cannot accept liability for any damage resulting from its use. The same applies to any person or company involved in preparing and editing this document. ELIWELL CONTROLS SRL reserves the right to make aesthetic or functional changes at any time without notice.

## CONDITIONS OF USE

#### Permitted use

For safety reasons the instrument must be installed and used in accordance with the instructions supplied. Users must not be able to access parts with dangerous voltage levels under normal operating conditions.

The device must be suitably protected from water and dust according to the specific application and only be accessible using special tools (except for the front keypad).

The device can be fitted to equipment for household use and/or similar use in the refrigeration sector and has been tested with regard to safety in accordance with the European harmonized reference standards.

#### Improper use

The use of the unit for applications other than those described above is forbidden. It should be noted that the relay contacts supplied with the device are functional and therefore exposed to potential faults. Any protection devices required to comply with product requirements or dictated by common sense due to obvious safety reasons should be installed externally.

## DISPOSAL



The appliance (or the product) must be disposed of separately in compliance with the local standards in force on waste disposal.

Eliwell Controls s.r.l.  
Via dell'Industria, 15 • Z.I. Paludi  
32016 Alpagò (BL) - ITALY  
T: +39 0437 986 111

[www.eliwell.com](http://www.eliwell.com)

#### Technical Customer Support:

T: +39 0437 986 300  
E: Techsuppliwell@se.com

#### Sales:

T: +39 0437 986 100 (Italy)  
T: +39 0437 986 200 (other countries)  
E: saleseliwell@se.com

